

Chief Judge: Josh Schraufnagel
Email: jschraufnagel@sces.net



Senior Obstacle Course

Mean Time: 10 minutes
Drop Dead Time: 12 minutes

Event Summary:

This is a de-energized event. The climber will climb a 45' pole equipped with three (3) eight (8) foot cross arms. The first cross arm will be mounted at 26' and equipped with a drop in pin with a polymer insulator. The second cross arm will be mounted at 32' and equipped with a 100-amp solid blade cut-out attached with an L bracket. The top cross arm will be mounted at 38' and equipped with a polymer dead end insulator attached to the arm with a 5/8 eye bolt. Pins and cotter keys must face in.

The climber is required to stop at each arm and relocate the arm mounted device to the opposite end of the arm. When the climber has both feet on the ground time will stop. The climber must carry a handline up with them and hang the handline off at each arm before any work is to be done. When all of the devices are moved, the climber can railroad the handline down to the ground.

Event Description:

1. The Lineman will have 5 minutes to set up.
2. The lineman may choose to start at the bottom arm or the top arm.
3. Time starts on the judge's signal with fall arrest system detached from the pole.
4. Handline must be hung off before starting any work other than climbing.
5. Time stops when the lineman has both feet on the ground.
6. All general rules apply.

Note: Per general rules, the handline must be hung prior to performing work on the structure.

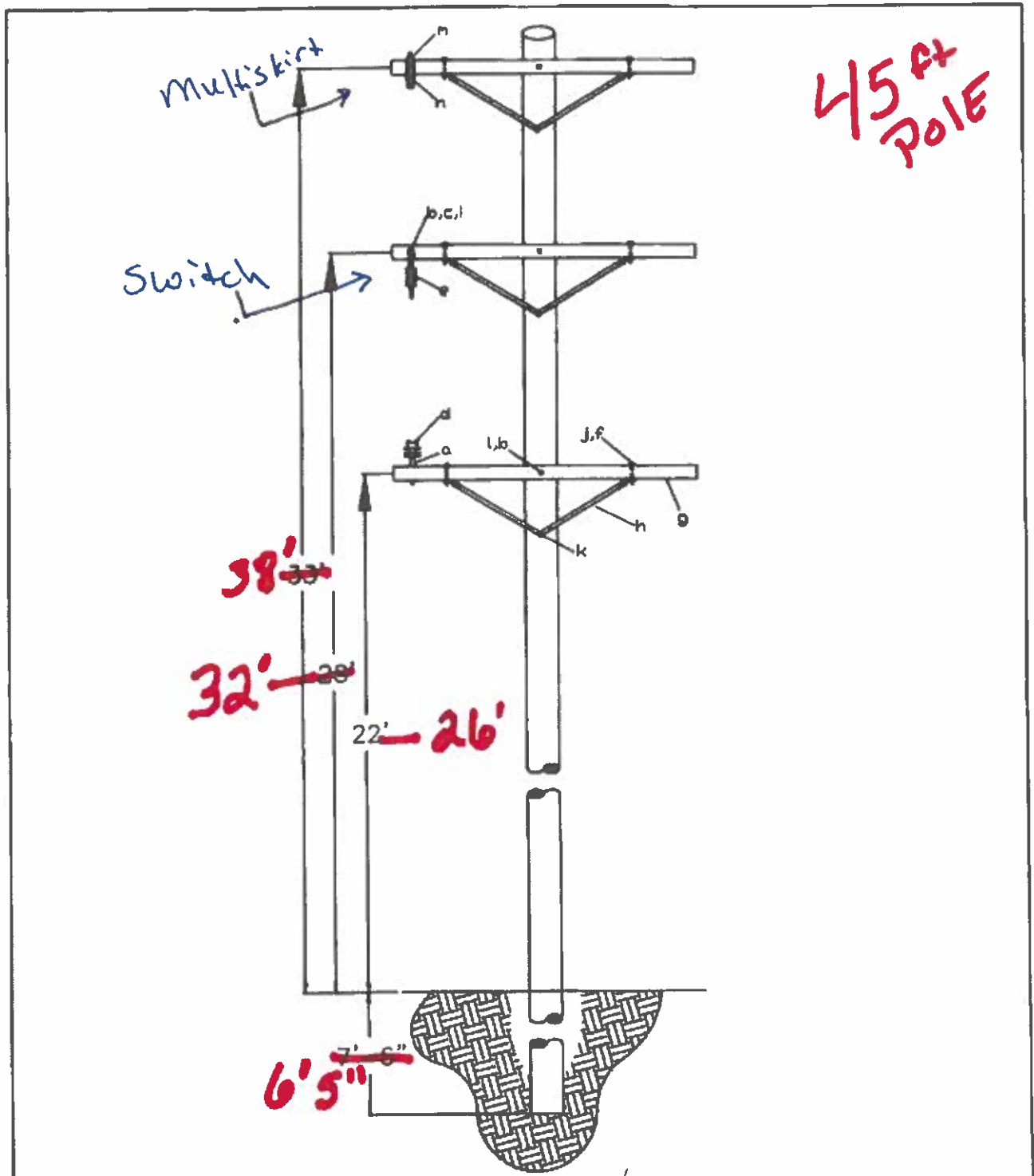

4/5 FT
POLE

REV	NAME	DATE	DESCRIPTION	DRAWN	---
1	---	10/15/21	Obstacle Pole Specifications	DATE	10/15/21
				CHKD	---
				BY	N/A
				SCALE	NTS
				SHT	1 of 2
				DRG. NO.	TFMR1